

NT4560 Gasoline Chainsaw

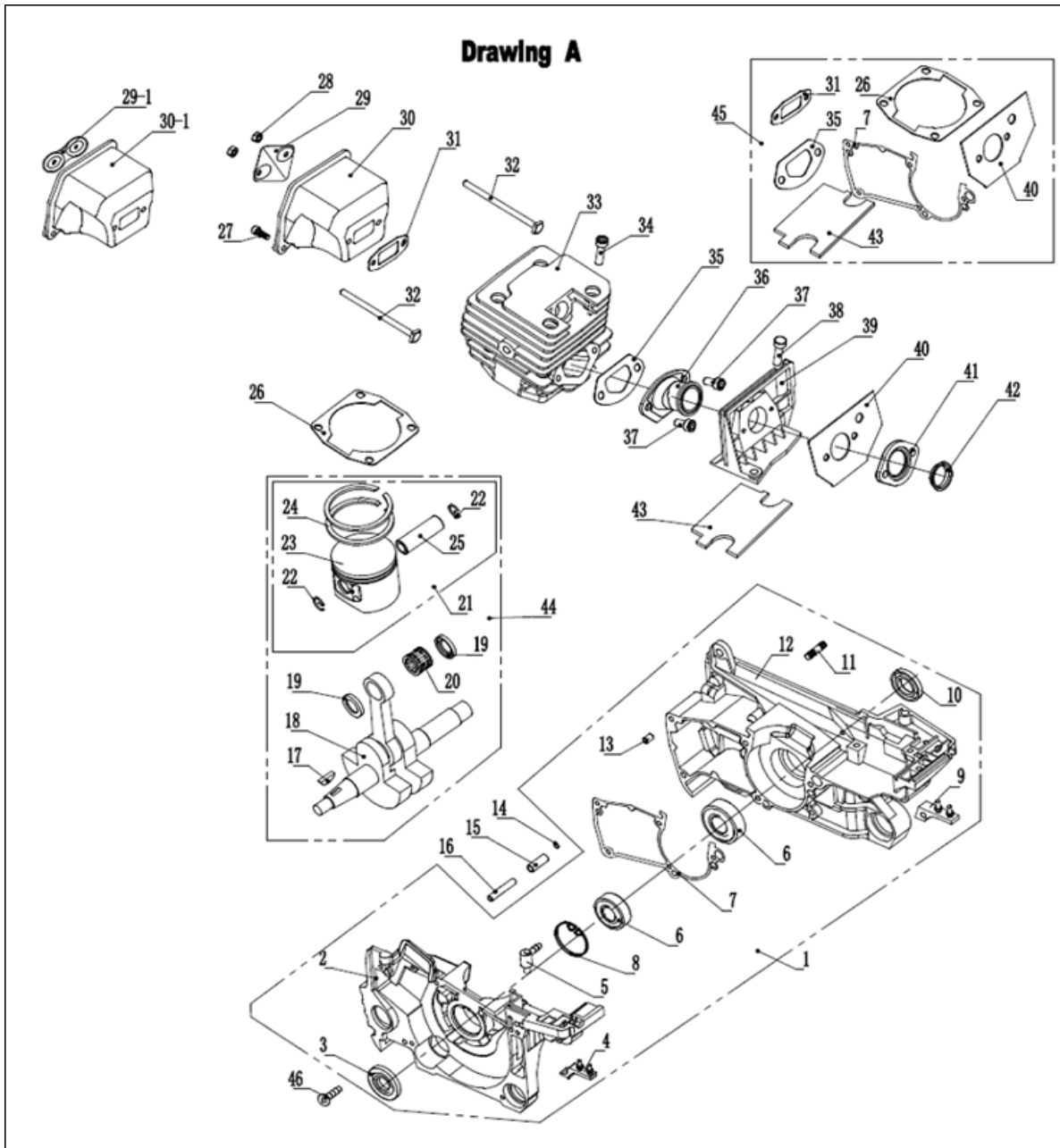

NT4560 Engine Parts



NO.	CODE	English name	Spanish name	Quantity
A		Engine parts	Partes del motor	
A01	12.4510.218.01	Crankcase	caja del cigüeñal	
A02	12.4510.201.01	Left crankcase	cárter izquierdo	
A03	96.10.153505.0	oil seal(L)	sello de aceite (L)	
A04	12.4510.706.01	stopper	tapón	
A05	12.4510.824.01	Elbow	codo	
A06	93.1.620200.01	bearing 6202	rodamiento 6202	
A07	12.4510.803.02	Crankcase gasket	junta de cárter	2
A08	95.63.35000.01	Snap ring 35	Anillo de resorte 35	
A09	12.4510.706.02	Stopper	tapón	

EXPERTOS EN EQUIPOS DE JARDINERIA Y AGRICULTURA

A10	96.10.152805.1	oil seal(R)	sello de aceite (R)	
A11	91.77.10.08301	stud M8x30	espárrago M8 x 30	
A12	12.4510.201.20	right crankcase	cárter derecho	
A13	94.10.06090.01	Pin 6x9	Pin 6 x 9	
A14	12.3800.609.01	Clip φ6	φ6 Clip	
A15	12.4510.817.01	thermal sleeve	manguito térmico	
A16	12.4510.711.03	vacuum pipe	tubo de vacío	
A17	94.77.031037.1	key 3x10	CUÑA 3 x 10	
A18	12.4510.353.01	crankshaft	cigüeñal	
A19	12.4510.308.01	washer	arandela	
A20	93.3.111500.01	bearing 11*15*12.5	RODAMIENTO AGUJAS 11 * 15 * 12,5	2
A21	12.4510.902.01	piston assy	CONJUNTO pistón	2
A22	95.73.11010.01	snap spring	PIN PASADOR PISTON	
A23	12.4510.243.01	piston	pistón	
A24	12.4510.351.01	piston ring	JUEGO DE ANILLOS	
A25	94.50.11340.01	piston pin	pasador de pistón	
A26	12.4510.803.01	Cylinder Gasket	JUNTA CILINDRO	
A27	91.32.30.05101	screw M5*10	tornillo M5 * 10	
A28	92.01.34.05001	Nut M5	tuerca M5	
A29	12.4510.310.02	Muffler cover	tapa del silenciador	
A29-1	12.4510.310.03	Muffler cover	tapa del silenciador	
A30	12.4510.352.01	Muffler	silenciador	
A30-1	12.4510.352.02	Muffler	silenciador	
A31	12.4510.803.06	Muffler Gasket	JUNTA SILENCIADOR	
A32	91.90.30.05871	Muffler bolt M5*87	Silenciador perno M5 * 87	
A33	12.4510.240.01	cylinder	cilindro	
A34	91.32.30.05201	screw M5*20	tornillo M5 * 20	
A35	12.4510.803.03	gasket	JUNTA	
A36	12.4510.710.01	Inlet pipe	tubo de entrada	
A37	91.32.30.05101	screw M5*10	tornillo M5 * 10	
A38	91.32.30.05141	screw M5*14	tornillo M5 * 14	
A39	12.4510.108.01	Inlet pipe bracket	soporte de tubo de entrada	
A40	12.4510.803.04	gasket	junta	
A41	12.4510.114.12	flange	brida	
A42	12.4510.308.02	Inlet pipe lining	ANILLO TUBO DE ENTRADA	
A43	12.4510.803.05	gasket	junta	
A45	12.4510.927.00	Gasket set for engine	Juego de juntas para el motor	
A46	91.32.30.05301	screw M5*30	tornillo M5 * 30	
	12.4510.609.02	sleeve hose	manguera de manga	
	12.4510.927.01	Gasket assembly	Junta de junta	5

NT4560 Ignition Module

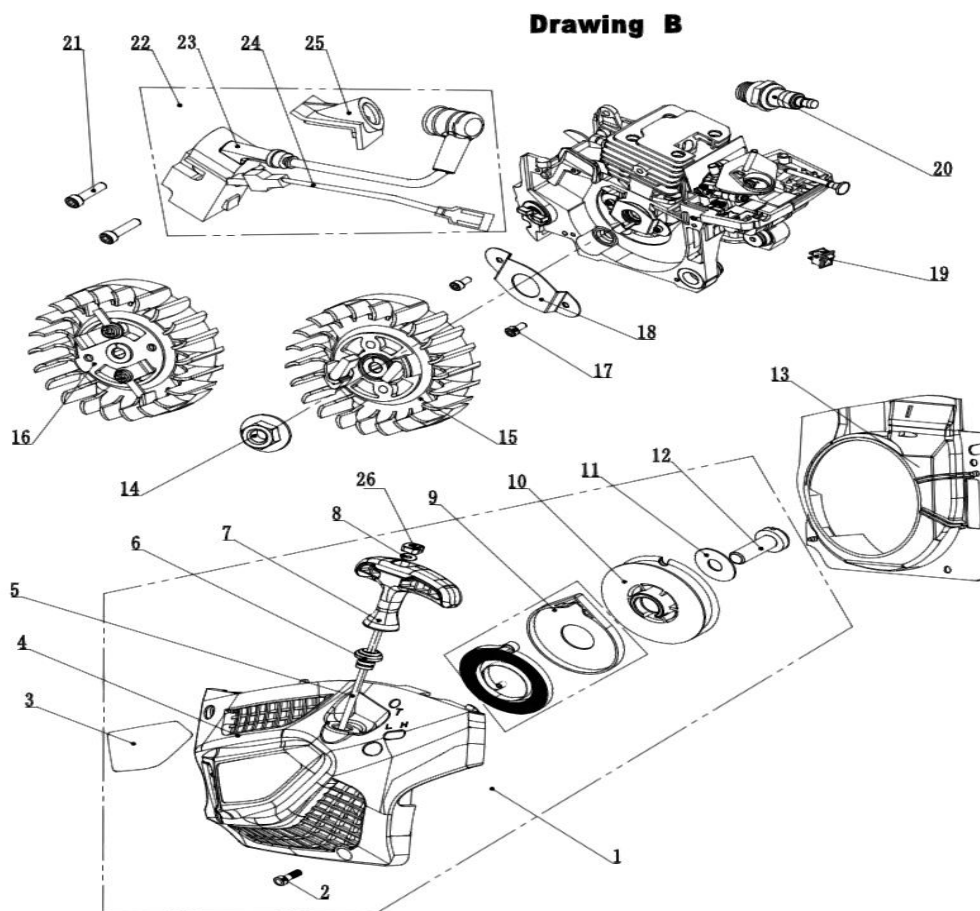

NO.	CODE	English name	Spanish name	Quantity
B		Ignition module	módulo de encendido	
B01	12.4510.918.01	Starter assy	ARRANQUE CPL	2
B02	91.32.30.05141	screw M5*14	tornillo M5 * 14	
B03		label	etiqueta	
B04	12.4540.102.10	Starter cover	TAPA DE ARRANQUE	
B05	12.3200.820.01	Starter rope	cuerda de arranque	
B06	12.4510.109.10	Bushing	AMORTIGUADOR	
B07	12.4540.105.01	starter grip	MANGO DE ACTIVACION	
B08	95.01.05100.00	flat washer 5	arandela plana 5	
B09	12.4510.620.01	Rewind spring assembly	RESORTE ARRANQUE	2
B10	12.4510.116.01	Starter reel	POLEA DE ARRANQUE	2
B11	95.01.05160.01	washer Ø5*16	arandela Ø5 * 16	
B12	91.63.32.48161	screw	tornillo	
B13	12.4540.114.11	fan cover	cubierta del ventilador	
B14	92.09.31.08011	Nut M8*1	Tuerca M8 * 1	
B15	12.4510.242.01	flying wheel (with iron paw)	VOLANTE CON TRINQUETES HIERRO	
B16	12.4510.242.06	flying wheel (with iron paw)	VOLANTE CON TRINQUETES HIERRO	
B17	91.32.30.04081	screw M4*8	tornillo M4 * 8	
B18	12.4510.310.01	oil seal plate	placa de sello de aceite	
B19	90.13.10100.01	Stop switch KCD1	Interruptor	

B20	90.12.11.20301	spark plug	bujía	
B21	91.32.30.05201	screw M5*20	tornillo M5 * 20	
B22	12.4510.420.02	Ignition assembly	BOBINA CPL	
B23	12.4510.420.02	Ignition	BOBINA	
B24	12.4510.402.02	Off cable	CABLE DE ENCENDIDO	
B25	12.4540.701.00	Rubber boot	CAPUCHON DE GOMA	
B26	12.4540.706.01	rubber pad	TAPON DE MANGO	

NT4560 Handle System

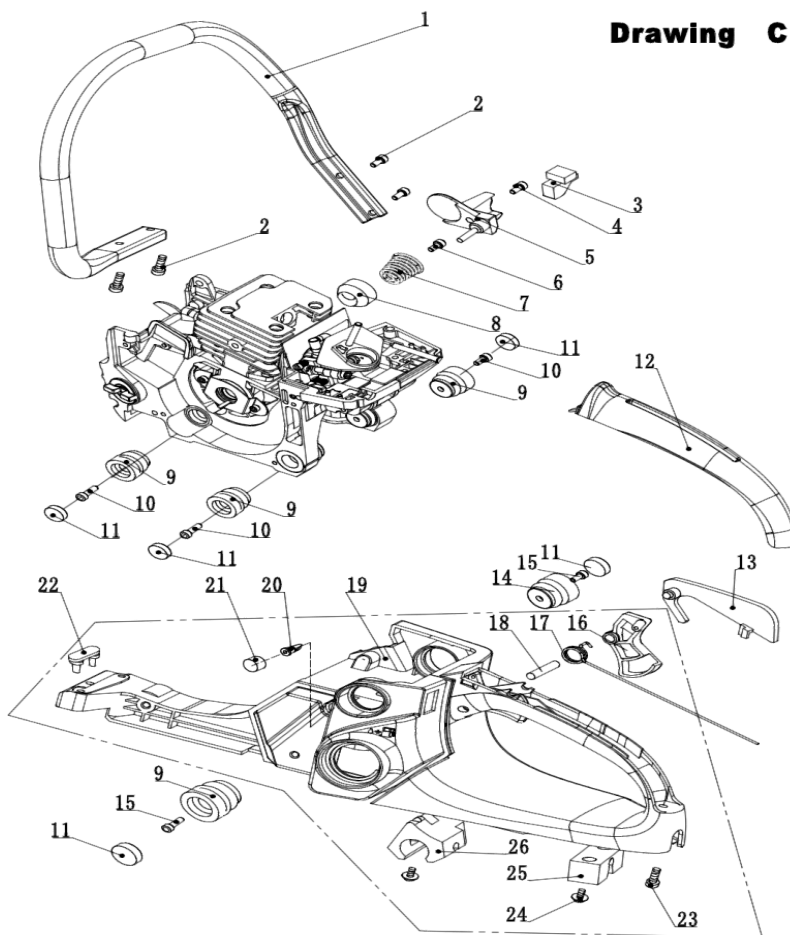

NO.	CODE	English name	Spanish name	Quantity
C		handle system	sistema de mango	
C01	12.4510.818.01	Front handle	mango delantero	
C02	91.63.32.48161	screw ST4.8x16	tornillo ST4.8 x 16	
C03	12.4510.703.04	Damper	Amortiguador	
C04	91.32.30.05141	screw M5*14	tornillo M5 * 14	
C05	12.4510.109.01	Chain catcher	TAPA RESORTE MANGO	
C06	91.63.32.48161	screw ST4.8*16	ST4.8 tornillo * 16	
C07	12.4510.612.01	Spring	RESORTE	10
C08	12.4510.31201	Spring base	BASE DE RESORTE	
C09	12.4510.703.01	Damper(short)	Amortiguador (corto)	10
C10	91.63.32.48161	screw ST4.8*16	ST4.8 tornillo * 16	
C11	12.4510.107.16	dust cap	tapón antipolvo	2

C12	12.4540.10.736	Rear handle cover	cubierta de la manija trasera	
C13	12.4540.106.21	throttle interlock arm	el brazo de bloqueo del acelerador	
C14	12.4510.703.02	Damper (long)	AMORTIGUADOR	10
C15	91.32.23.05120	screw M5*12	tornillo M5 * 12	10
C16	12.4540.106.02	throttle lever	la palanca del acelerador	
C17	12.3800.603.01	Throttle spring	RESORTE del acelerador	
C18	94.10.0624.001	pin 6x24	pin 6x24	
C19	12.4540.101.01	Fuel tank	depósito de combustible	
C20	12.4510.708.01	ventilation valve	VALVULA VENTILACION	
C21	12.3710.805.01	valve block	TAPA VALVULA VENTILACION	
C22	12.4510.706.03	Pin	pasador	
C23	91.63.32.48191	screw ST4.8x19	tornillo ST4.8 x 19	
C24	91.29.22.40080	screw ST4.0x8	ST4.0 tornillo x 8	
C25	12.4540.707.02	Spanner fixed rubber(back)	BLOQUE DE GOMA	
C26	12.4540.707.01	Spanner fixed rubber(front)	BLOQUE DE GOMA	

NT4560 Fuel System

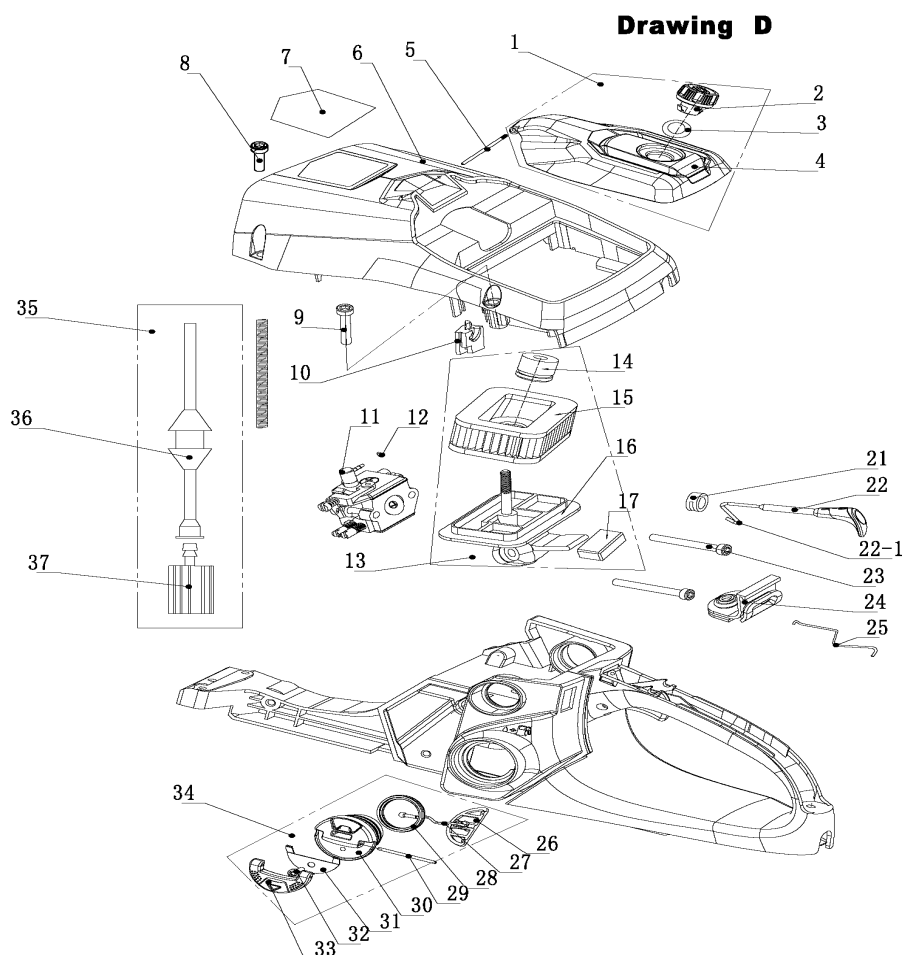

NO.	CODE	English name	Spanish name	Quantity
D		Fuel system	sistema de combustible	
D01	12.4540.125.01	Air filter cover assy	TAPA FILTRO DE AIRE CPL	
D02	12.4540.104.10	knob	perilla	
D03	12.3800.120.01	Washer	arandela	
D04	12.4540.107.14	Air filter cover	tapa del filtro de aire	
D05	12.4540.314.11	pin	PASADOR	
D06	12.4540.102.02	Cylinder cover	CARCASA CILINDRO	
D07		label	etiqueta	
D08	91.32.30.05141	screw M5*14	tornillo M5 * 14	
D09	91.32.30.05301	screw M5*30	tornillo M5 * 30	
D10	12.4540.701.10	Sealing plate	placa de sellado	
D11	12.4510.880.01	carburetor	carburador	
D12	12.3800.609.01	Clip φ6	Clip	
D13	12.4540.904.02	air filter assy	CONJUNTO filtro de aire	
D14	12.4540.702.10	Fixing sleeve	MANGO DE FIJACION	
D15	12.4540.805.01	air filter	FILTRO DE AIRE	
D16	12.4540.115.10	air filter seat	asiento de filtro de aire	
D17	12.4510.703.05	bumper block	bloque de tope	
D21	12.4510.704.01	rubber sleeve	manguito de goma	
D22	12.4540.123.10	Choke lever	Palanca del CHOKE	
D22-1	12.4510.607.02	Choke lever(inserted)	palanca CHOKE (insertada)	
D23	91.32.30.05501	screw M5*50	tornillo M5 * 50	
D24	12.4510.707.01	Dustproof rubber block	bloque de caucho a prueba de polvo	
D25	12.4510.607.01	The throttle lever	palanca del acelerador	
D26	12.3200.109.01	Fuel tank cap hangers	tapa del depósito de combustible	
D27	12.3200.820.00	Connection string	cadena de conexión	
D28	12.4540.702.11	Sealing ring	anillo de sellado	
D29	12.4540.314.11	pin	PASADOR	
D30	12.4540.122.20	Fuel tank cap	tapón del depósito	
D31	12.4540.608.11	Spring piece	TAPA METRALLA	
D32	91.23.32.36060	Screw ST3.6*6	Tornillo ST3.6 * 6	
D33	12.4540.109.30	flipping cover	METRALLA TAPA COMBUSTIBLE	
D34	12.4540.929.00	Fuel tank cover assy	TAPA COMBUSTIBLE CPL	
D35	12.4510.939.01	Fuel filter with hose	MANGUERA COMBUSTIBLE CPL	
D36	12.4510.711.01	Fuel hose	manguera de combustible	
D37	90.14.04022.01	Pick-up body	FILTRO DE COMBUSTIBLE	

NT4560 Oil pump system

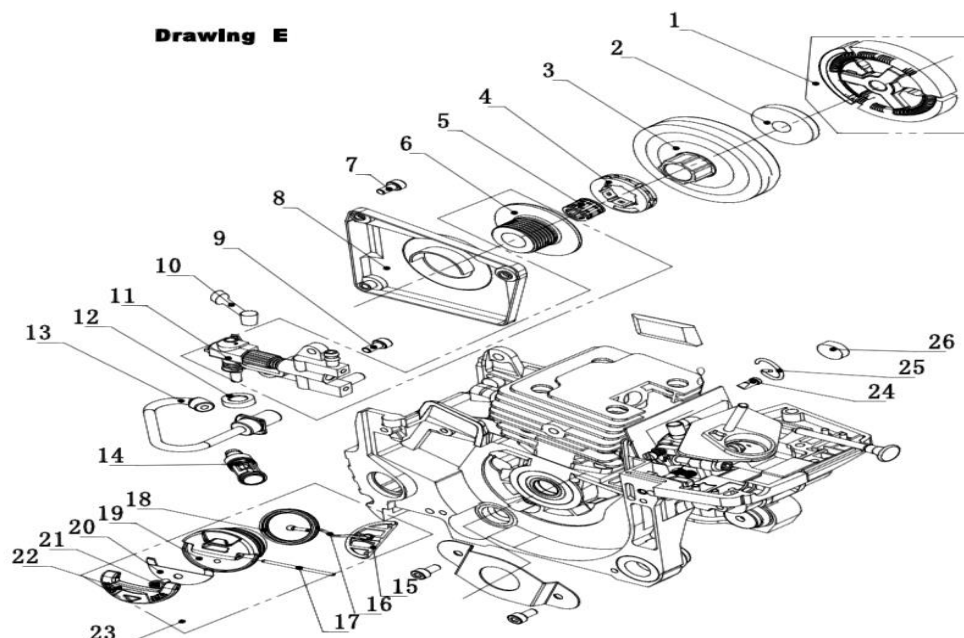

NO.	CODE	English name	Spanish name	Quantity
E		Oil pump system	sistema de bomba de aceite	
E01	12.4510.811.01	clutch assembly	EMBRAGUE	10
E02	12.4510.308.03	clutch gasket	JUNTA ANTOFRICCION	
E03	12.4510.316.01	Clutch driven plate	CAMPANA	
E04	12.4510.776.01	sprocket	piñón	
E03	12.4510.316.01	Clutch driven plate	CAMPANA	
E04	12.4510.776.01	sprocket	piñón	
E05	93.4.121515.01	needle bearing12*15*15	RODAMIENTO DE aguja * 15 * 15	
E06	12.4510.119.01	worm	SIN FIN	
E07	91.32.30.04101	screw M4x10	tornillo M4 x 10	
E08	12.4510.107.18	Oil pump cover	tapa de la bomba de aceite	
E09	91.32.30.04141	screw M4x14	tornillo M4 x 14	
E10	12.4510.711.03	spray nozzle	boquilla de pulverización	
E11	12.4510.930.01	oil pump	bomba de aceite	10
E12	12.4510.809.01	sponge1	FILTRO ESPUMA	
E13	12.4510.711.02	inlet pipe	MANGUERA ENTRADA ACEITE	
E14	12.4510.805.10	oil filter	filtro de aceite	
E15	12.3200.109.01	Oil tank cap hangers	SOPORTE TAPA ACEITE	
E16	12.3200.820.00	connection string	cadena de conexión	
E17	12.4540.314.12	pin	Pasador	
E18	12.4540.702.10	seal gasket	junta de estanqueidad	
E19	12.4540.122.10	oil tank cover	tapa del depósito de aceite	
E20	12.4540.608.10	Spring piece	TAPA METRALLA	
E21	91.23.32.36060	screw	tornillo	
E22	12.4540.109.20	flipping cover	cubierta de volteo	
E23	12.4540.929.10	oil tank cap assy	TAPA DE ACEITE CPL	
E24	12.4510.708.01	air vent nozzle	boquilla de ventilación de aire	
E25	95.73.10100.01	snap sprin	PIN	
E26	12.4510.809.02	sponge 2	ESPUMA	

NT4560 Braking system

EXPERTOS EN EQUIPOS DE JARDINERIA Y AGRICULTURA

F24	12.4510.107.19	brake spring gland	TAPA DEL FRENO	
F25	12.4510.307.01	Baffle pin sets	PASADOR	
F26	12.4510.126.01	main and sub brake lever	palanca principal y sub freno	
F27	95.43.03506.01	snap ring 3.5	PIN 3.5	
F28	12.4510.314.02	spacer pin	PASADOR	
F29	12.4510.319.01	spacer board	Junta espaciador	
F30	12.4510.702.02	rubber gasket	junta de goma	
F31	95.43.04006.01	snap ring 4	PIN 4	
F32	95.01.06180.01	washer 6x18	arandela 6 x 18	
F33	12.4510.603.02	brake torsion spring	RESORTE torsión de freno	
F34	12.4510.934.01	adjusting screw assembly	tornillo de ajuste de componentes	
F35	91.63.32.42081	screw ST4.2x8	ST4.2 tornillo x 8	
F36	12.4510.803.07	gasket	junta	